

# 8 Station Cardio and Strength Circuit

DFP-0060S

This compact outdoor fitness circuit delivers a complete full body workout in one efficient layout. Combining cardio, strength, and mobility stations, it encourages users to move through a variety of exercises that build endurance, improve strength, and support overall wellbeing. Suitable for a wide range of fitness levels, the design promotes inclusive community use while helping activate public spaces and encourage healthier lifestyles.

## Specifications

Fall zone: 60.9m<sup>2</sup>

## Play Types



\*All information is commercial in confidence and is the property of The Play Collective. For details regarding Australian standards, warranties, insurances, QA and installation, please contact your local office. All information is correct as at February 2024.

# 8 Station Cardio and Strength Circuit

DFP-0060S



Elevation

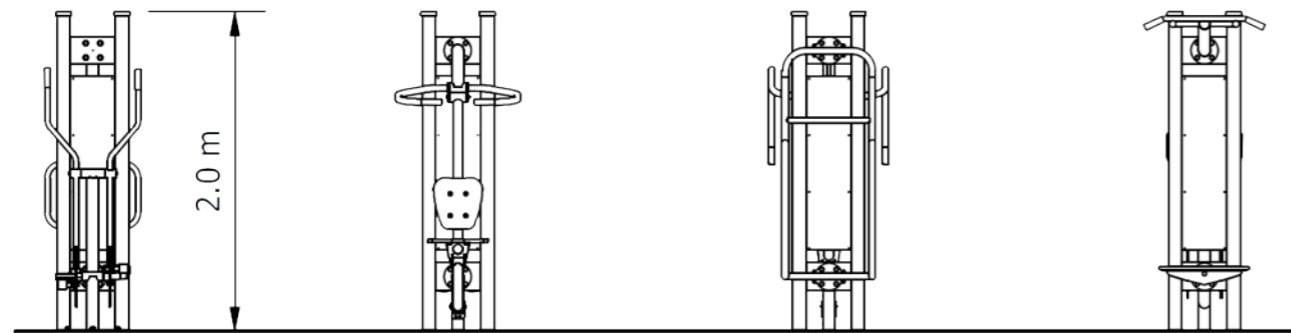

Plan View

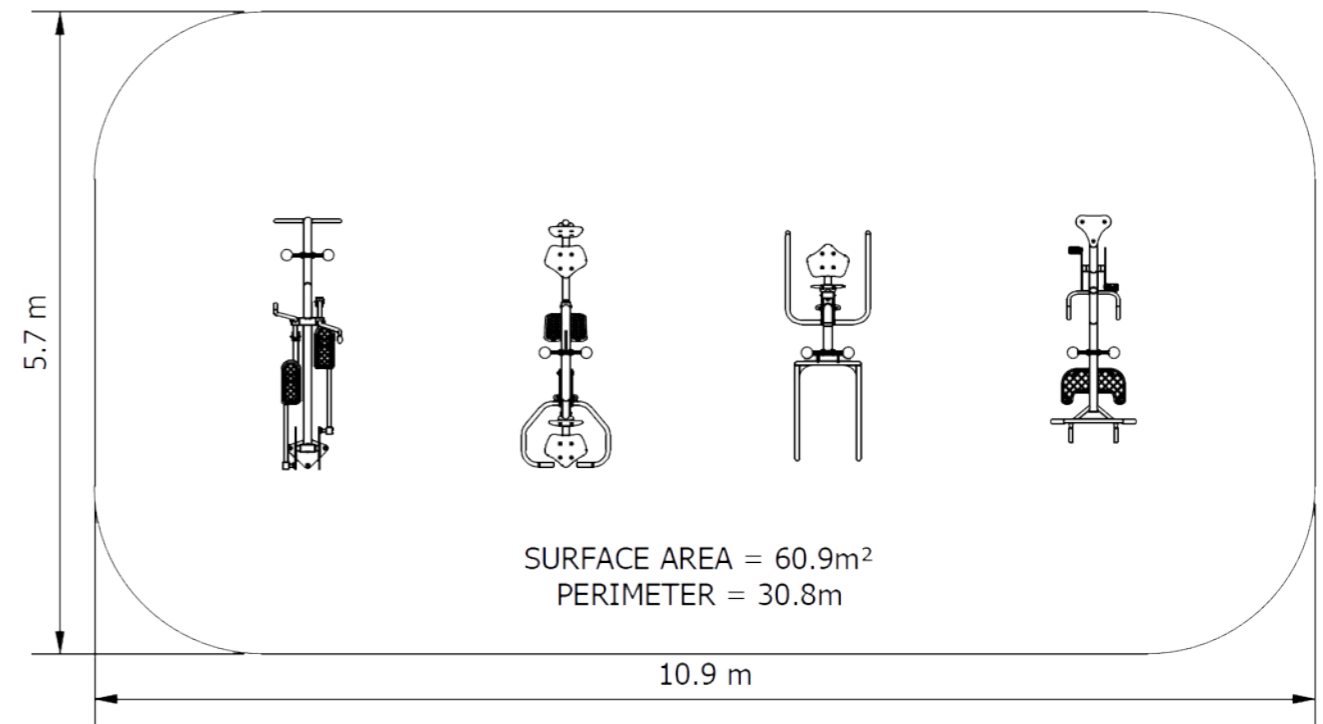

To learn more about our warranty, compliance, materials, or colour palette and customisation options, contact PlayCo:

1800 655 041 | [hello@playco.com.au](mailto:hello@playco.com.au) | [playco.com.au](http://playco.com.au)

