

Big Leg Swing - 2 Bays, Adult Height with Birds Nest + 1x Strap Seat

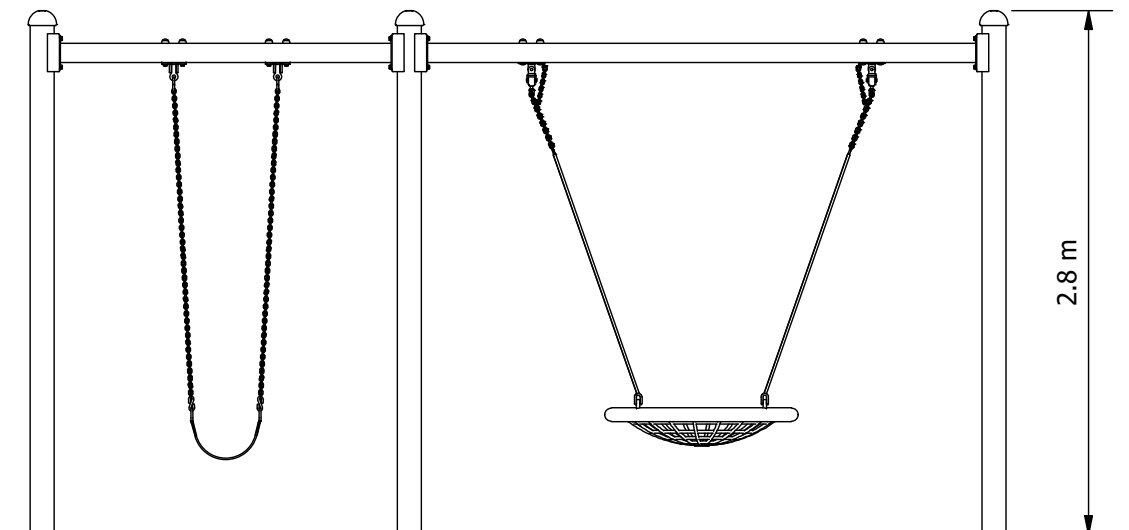

EQUIPMENT INVENTORY			
ITEM	DESCRIPTION	QTY	FHF (mm)
1	Birds Nest Swing Seat	1	1540
2	Big Leg Swing Adult (2 Bay Single/Birds Nest)	1	N/A
3	Strap Swing Seat	1	1555

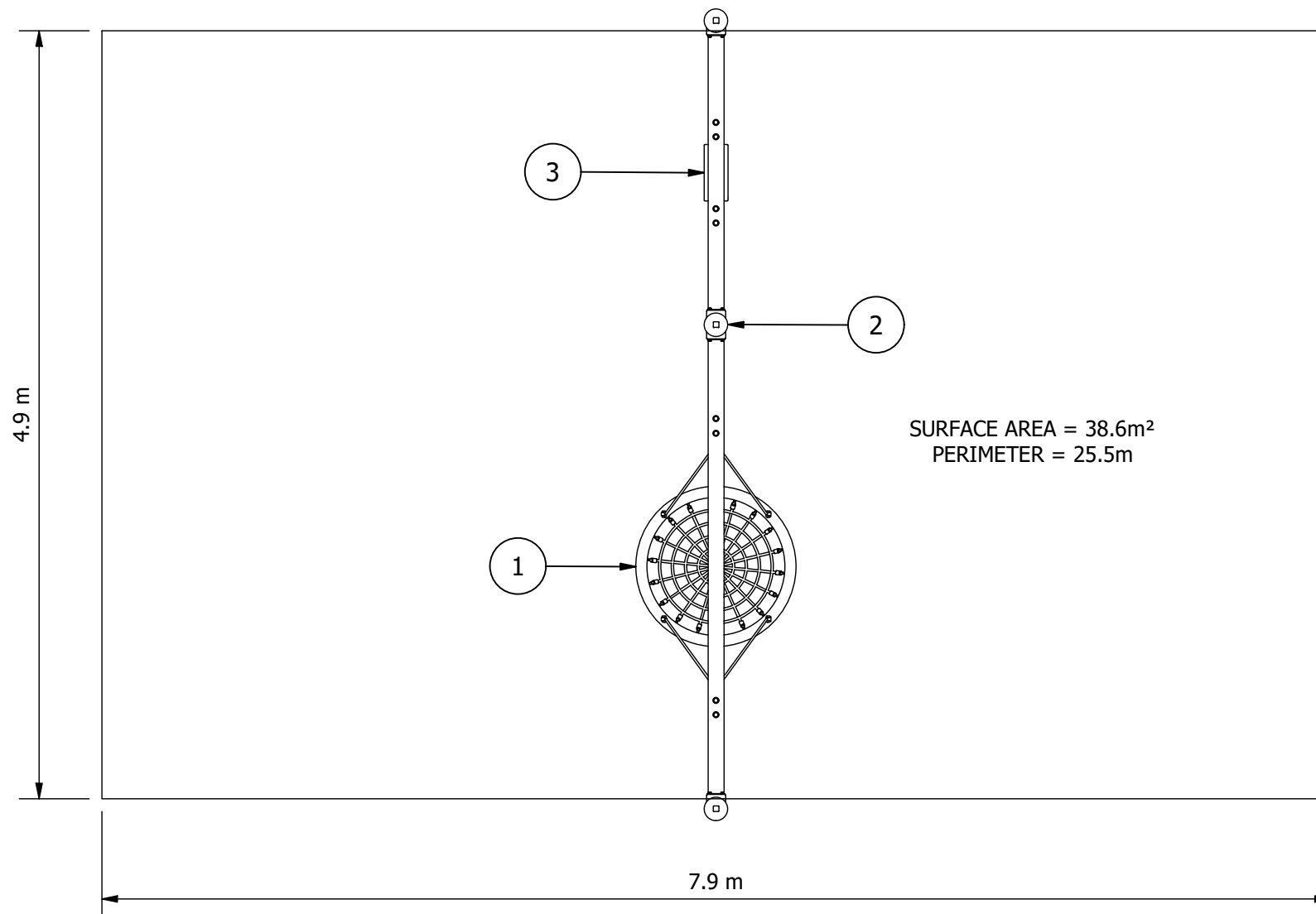

ELEVATION:

- RECOMMENDED MINIMUM SHADE CLEARANCES:
- 2.5M FROM ANY ACCESSIBLE PART OF THE EQUIPMENT TO ANY CLIMBABLE PART OF THE SHADE STRUCTURE
 - 1.5M FOR ALL OTHER SITUATIONS

Site Layout is indicative only & subject to change.
This design is confidential & subject to Copyright.



PLAYGROUND DESIGN COMPLIANT
WITH AS 4685:2021

Design Plan (Concept)

Design No:

SWGB021-B

Drawn by: **S.P.**

Date drawn: **20/03/2024**