

EQUIPMENT INVENTORY			
ITEM	DESCRIPTION	QTY	FHF (mm)
1	PS VERTICAL ROPE CLIMBER 1600	1	1600
2	PS Cable Rope Net Climber 2000 U Shape	1	2533
3	PS Ladder 1600	1	1600
4	PS Steel Pcoat Platform	2	1600
5	PS Vertical Rock Wall 1600	1	1600
6	PS Slide Big Dipper 1600 RM with Extended Barriers	1	1600/1000
7	PS Climbing Rings 1600	1	1720
8	PS Sliding Pole 1600	1	1830

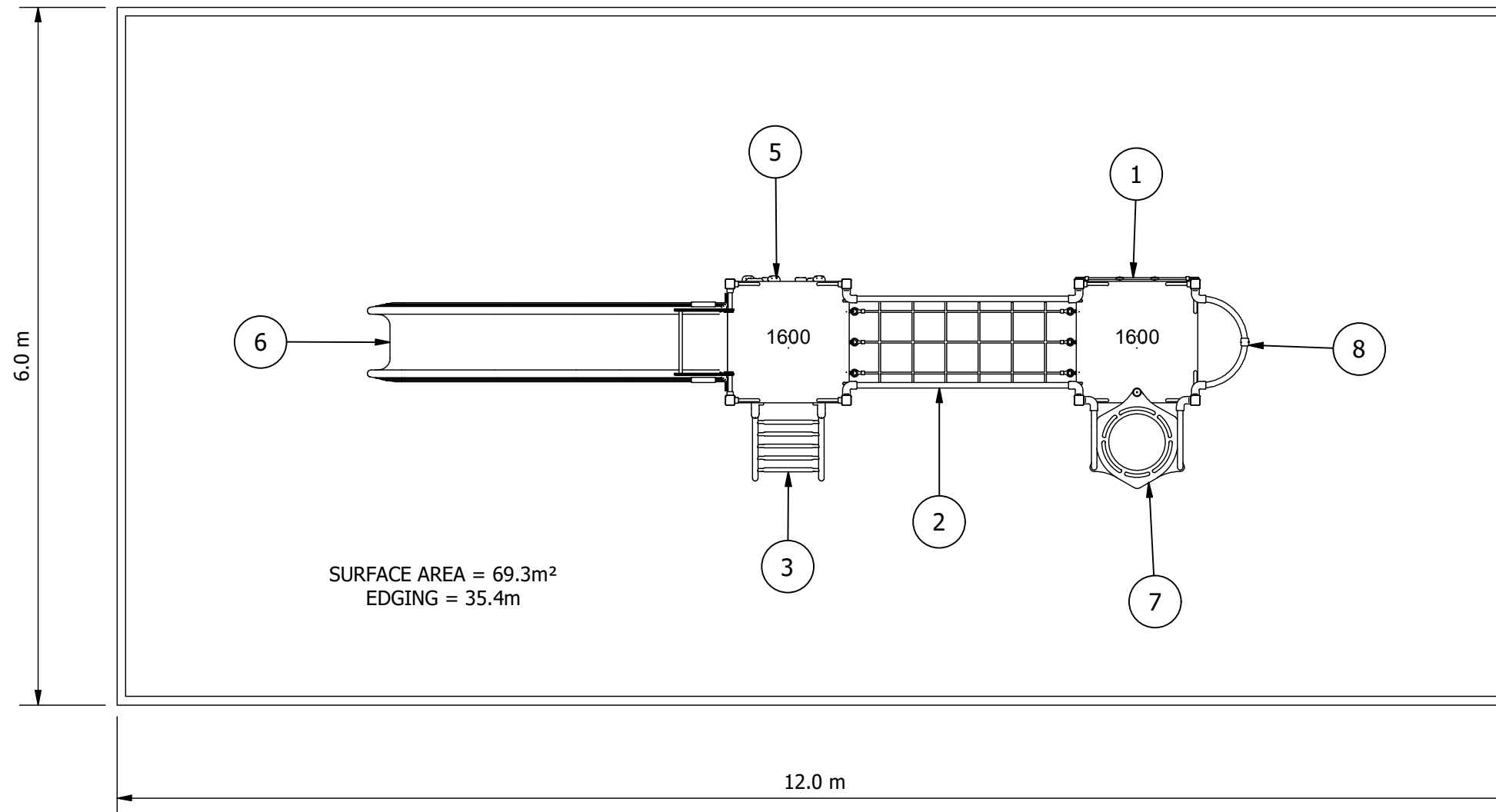

Site Layout is indicative only & subject to change.
This design is confidential & subject to Copyright.

PLAYGROUND DESIGN COMPLIANT
WITH AS 4685:2021

SCALE BAR 0 1 5 m
1:50@A3

Design Plan (Concept)

Design No:

SCH003-0

Drawn by: **C.M.**

Date drawn: **24/01/2024**