

EQUIPMENT INVENTORY			
ITEM	DESCRIPTION	QTY	FHF (mm)
1	FITX Leg Raises	1	240
2	FITX Leg Raises - Sign	1	N/A

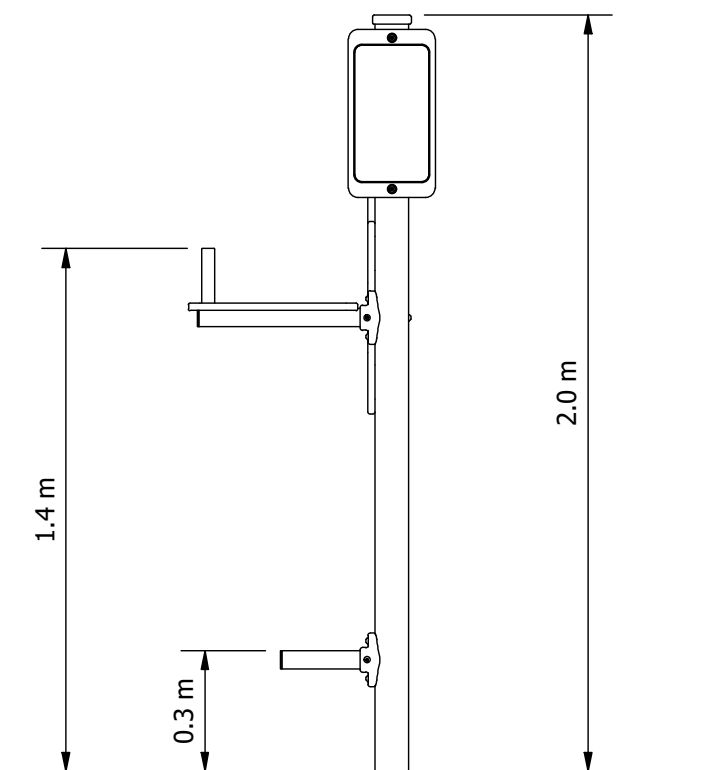

**ELEVATION**

- RECOMMENDED MINIMUM SHADE CLEARANCES
- 2.5M FROM ANY ACCESSIBLE PART OF THE EQUIPMENT TO ANY CLIMBABLE PART OF THE SHADE STRUCTURE
  - 1.5M FOR ALL OTHER SITUATIONS

Site Layout is indicative only & subject to change.  
This design is confidential & subject to Copyright.

FITNESS DESIGN COMPLIANT  
WITH AS 16630:2021.



**Design Plan**

Design No: **FITX020-A** | Drawn by: **S.P.**  
Date drawn: **16/07/2021**