

Dual Rider Spring Rocker

EQUIPMENT INVENTORY		
DESCRIPTION	QTY	FHF (mm)
DUAL RIDER - HDPE - IN GROUND	1	600

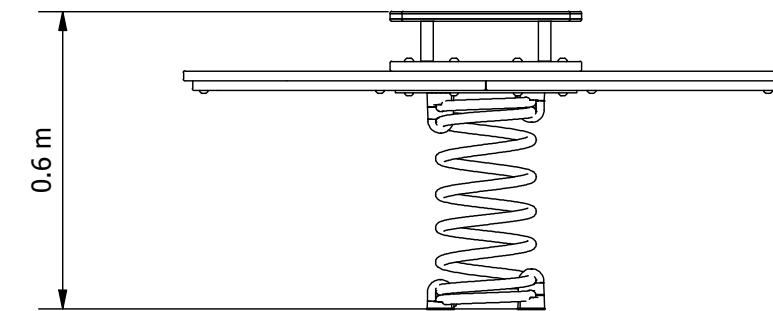
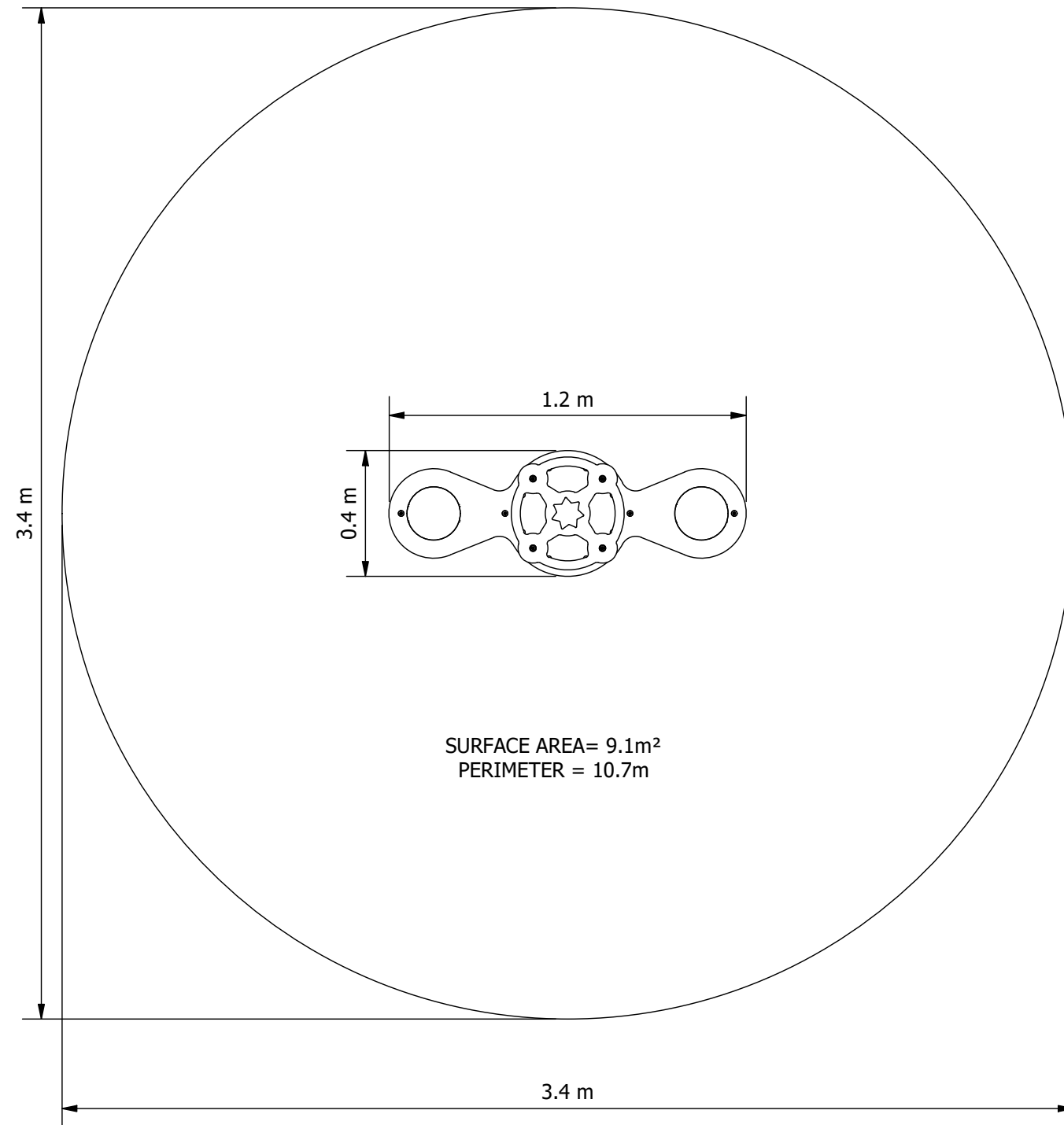

ELEVATION

RECOMMENDED MINIMUM SHADE CLEARANCES:

- 2.5M FROM ANY ACCESSIBLE PART OF THE EQUIPMENT TO ANY CLIMBABLE PART OF THE SHADE STRUCTURE
- 1.5M FOR ALL OTHER SITUATIONS

Site Layout is indicative only & subject to change.

This design is confidential & subject to Copyright.

SCALE BAR
1:20@A3



PLAYGROUND DESIGN COMPLIANT
WITH AS 4685:2021

Design Plan (Concept)

Design No:

SPR0179FBA-0

Drawn by: **C.M.**

Date drawn: **21/11/2024**