

Star Rider Spring & Bounce

Spring and bouncing equipment provides a fun and stimulating way for children to improve their balance and coordination. The rocking motion helps to improve children's vestibular system, which is responsible for their sense of balance, and can also help to improve their gross motor skills.

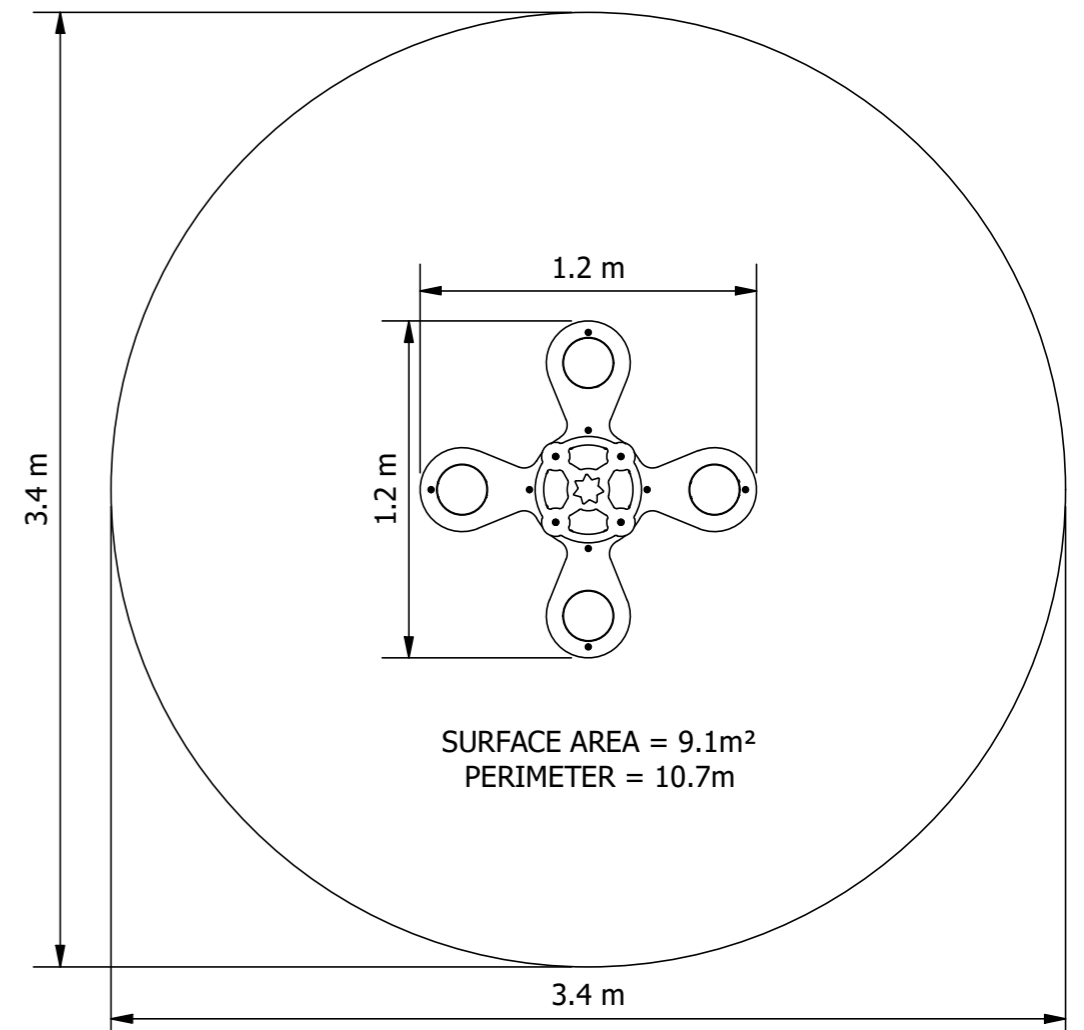

Product Code: SPR0177FBA

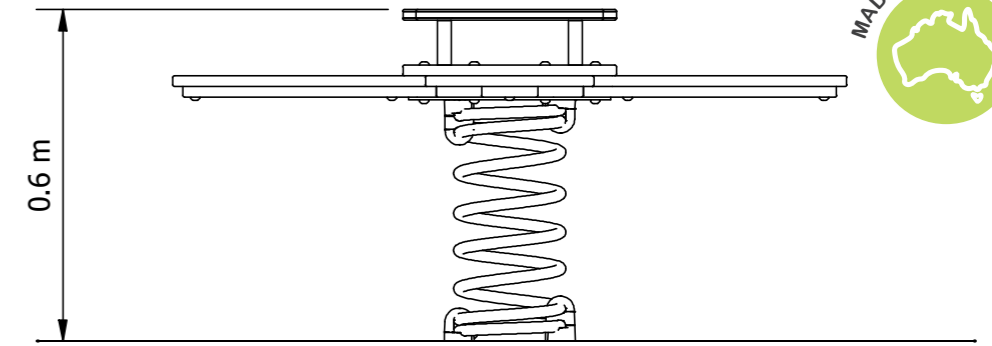

Required Space
3.4m diameter



Area
9.1m²



Age Group
2+



Max FHoF
600mm



Equipment Height
600mm