

Motorbike Spring Rocker

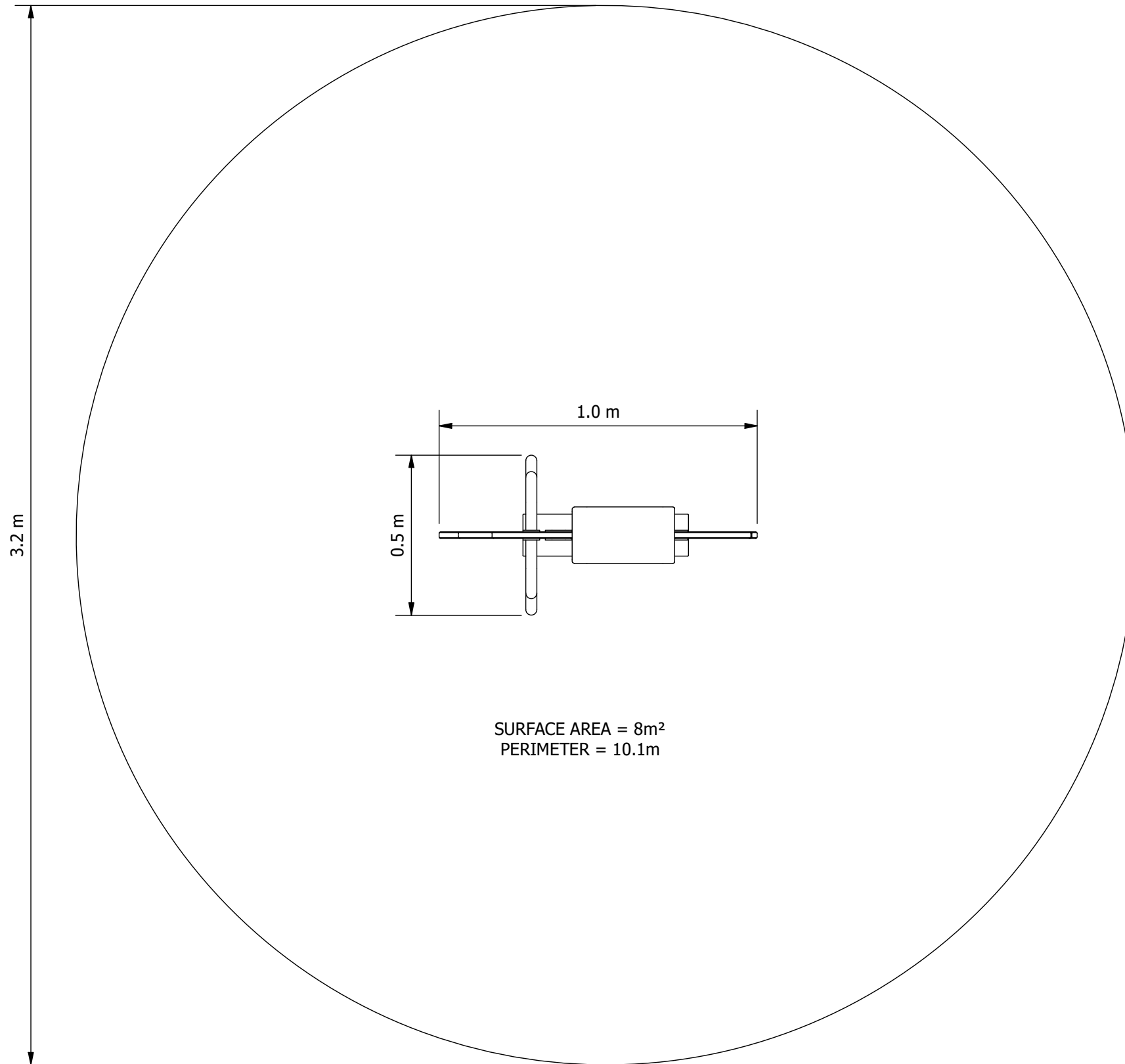

EQUIPMENT INVENTORY			
ITEM	DESCRIPTION	QTY	FHF (mm)
1	Motorbike Rocker	1	600

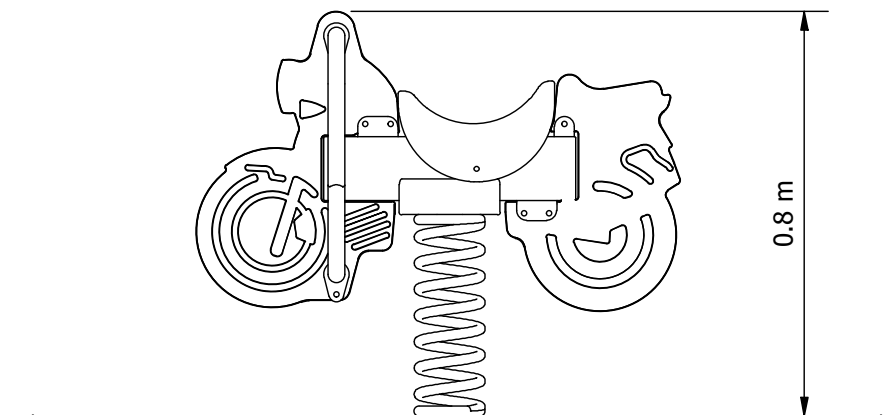

ELEVATION:

RECOMMENDED MINIMUM SHADE CLEARANCES

- 2.5M FROM ANY ACCESSIBLE PART OF THE EQUIPMENT TO ANY CLIMBABLE PART OF THE SHADE STRUCTURE
- 1.5M FOR ALL OTHER SITUATIONS

Site Layout is indicative only & subject to change.
This design is confidential & subject to Copyright.

SCALE BAR 1:15@A3



PLAYGROUND DESIGN COMPLIANT
WITH AS 4685:2021

Design Plan

Design No:

SPR0017FBA-B

Drawn by: **S.P.**

Date drawn: **1/06/2022**