

# Two Seat Rocker

EQUIPMENT INVENTORY		
DESCRIPTION	QTY	FHF (mm)
Two Seat Rocker	1	600

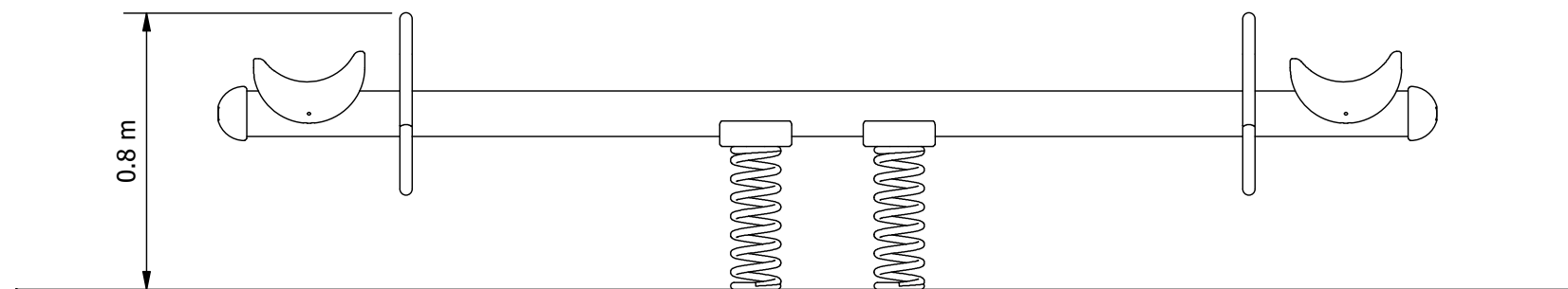
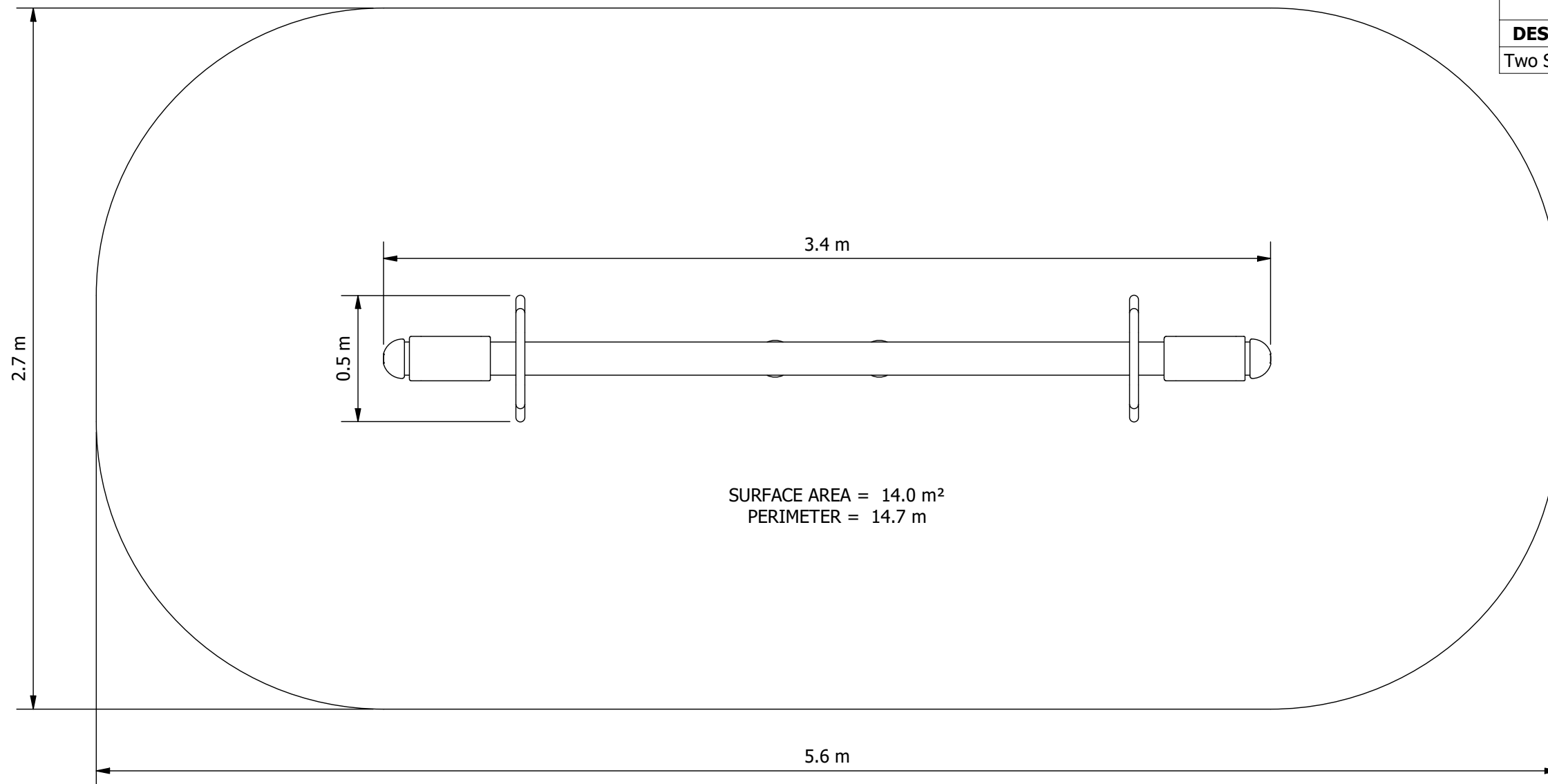

**ELEVATION:**

- RECOMMENDED MINIMUM SHADE CLEARANCES
- 2.5M FROM ANY ACCESSIBLE PART OF THE EQUIPMENT TO ANY CLIMBABLE PART OF THE SHADE STRUCTURE
  - 1.5M FOR ALL OTHER SITUATIONS

Site Layout is indicative only & subject to change.  
This design is confidential & subject to Copyright.

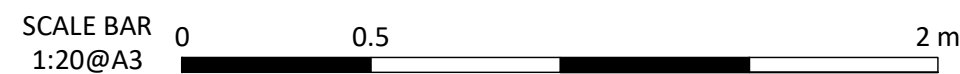

PLAYGROUND DESIGN COMPLIANT  
WITH AS 4685:2021

**Design Plan**

Design No: **SPR0001FBA-A**

Drawn by: **S.J.**

Date drawn: **1/06/2022**