

Revolving Sand Table Sensory & Learning

Sensory and learning play equipment provide children with opportunities to explore and learn through their senses. They are designed to stimulate children's sense of touch, sight and sound and can also help to develop their fine and gross motor skills, hand-eye coordination, and problem-solving abilities. Children are encouraged to explore and have fun, while building their sensory processing and cognitive development.

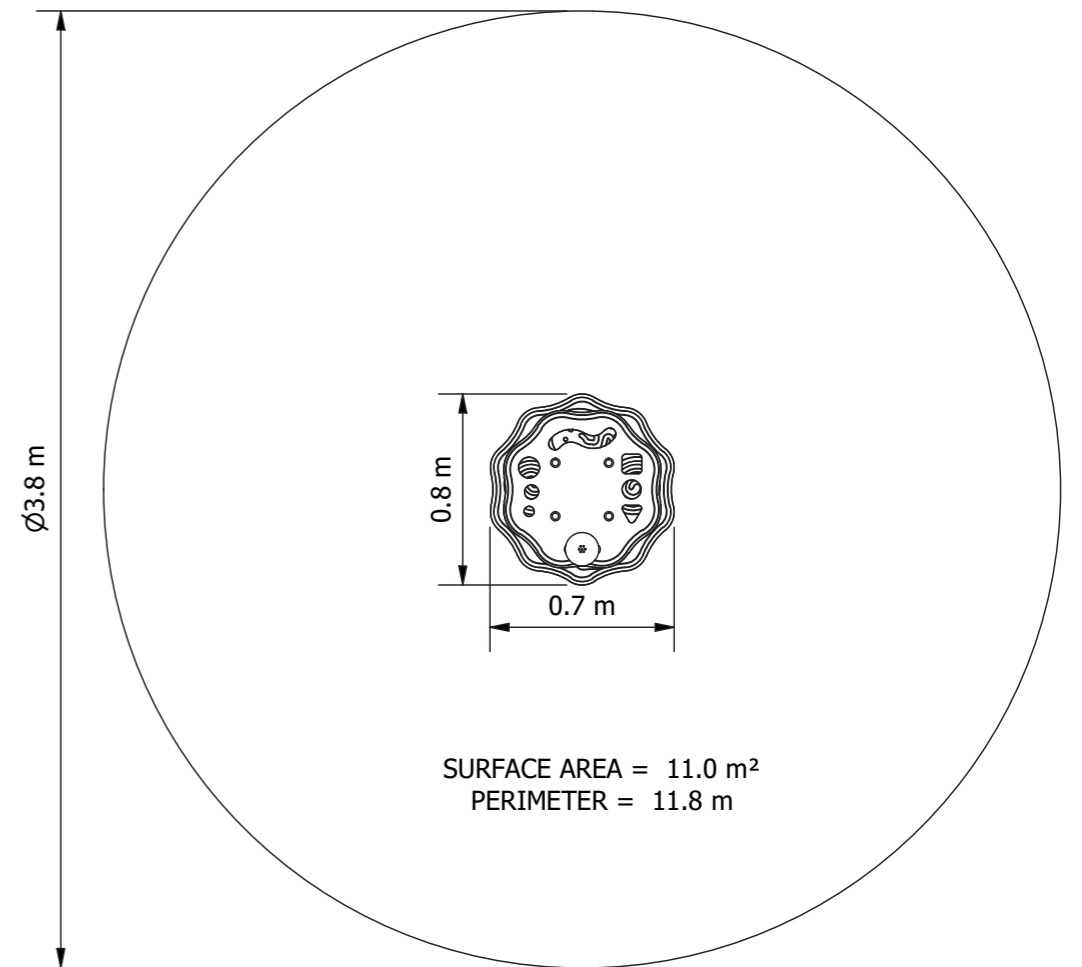

Product Code: FRN0030FBA

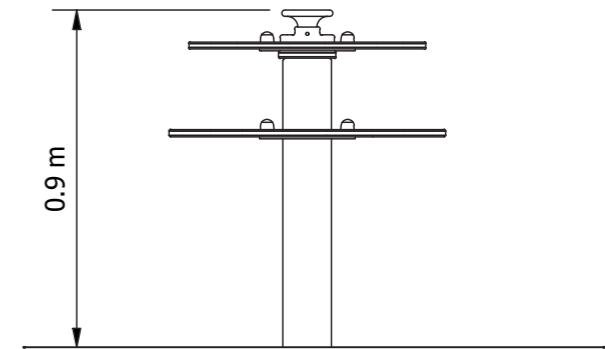
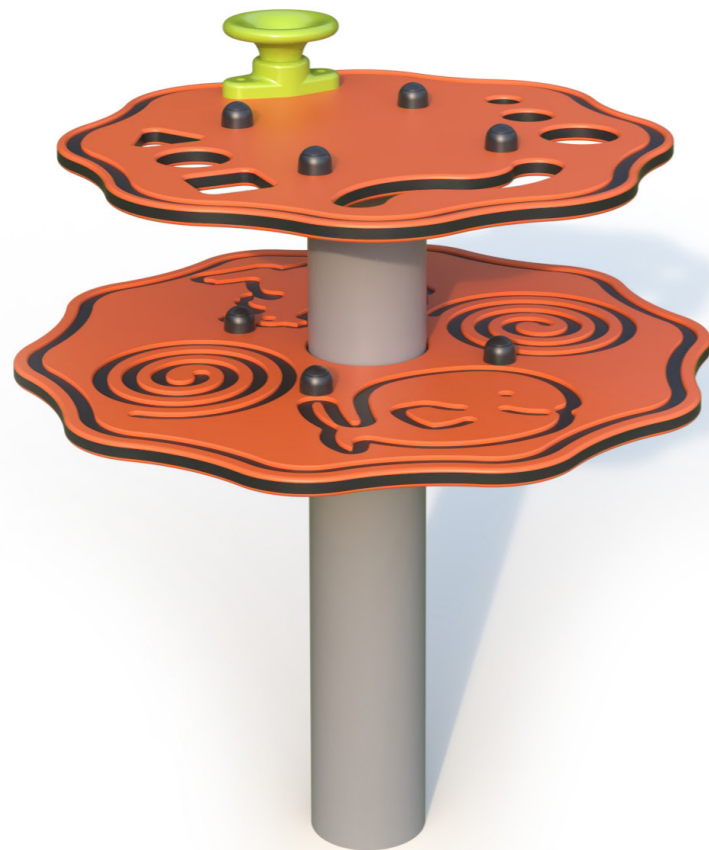

Required Space
3.8m diameter



Area
11.0m²



Age Group
2+



Max FHoF
N/A



Equipment Height
880mm

